

Homework Helpers

**Grade 3
Module 7**

G3-M7-Lesson 1

1. A museum uses 6 trucks to move paintings and sculptures to a new location. They move a total of 24 paintings and 18 sculptures. Each truck carries an equal number of paintings and an equal number of sculptures. How many paintings and how many sculptures are in each truck?

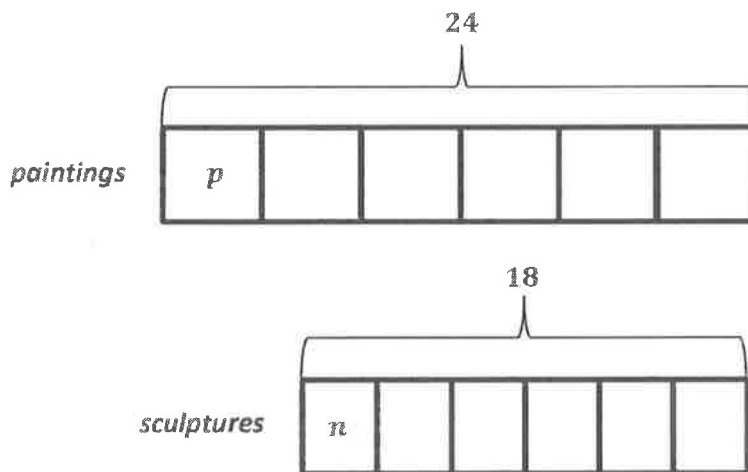

I can use the Read-Draw-Write (RDW) process to solve. As I read the problem, I can visualize a picture of the problem in my mind. I know it's helpful to reread the problem in case I missed anything or didn't understand the information completely. Then I can ask myself, "What can I draw?"

p represents the number of paintings in each truck

$$24 \div 6 = p$$

$$p = 4$$

n represents the number of sculptures in each truck

$$18 \div 6 = n$$

$$n = 3$$

I can figure out what information is known and unknown using my drawing. I can represent my unknowns using letters. I know there are a total of 24 paintings and 18 sculptures. They are equally placed into 6 trucks. I know the totals and that the number of groups is 6. So my unknown is the size of each group.

Next, I can write number sentences based on my drawings.

The final step of the Read-Draw-Write (RDW) process is to write a sentence with words to answer the problem. I can reread the question to be sure that my sentence answers it. This also gives me a chance to look back at my calculation to make sure that my answer is reasonable.

There are 4 paintings and 3 sculptures in each truck.

2. Christopher's father gives the cashier \$30 to pay for 7 keychains from the gift shop. The cashier gives him \$9 in change. How much does each keychain cost?

I know there are many ways to draw and solve this problem, but I want to draw a model that is most helpful to me.

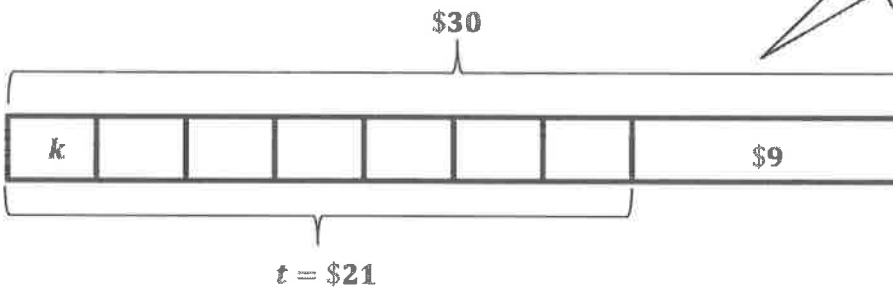

t represents the total cost of 7 keychains

$$\begin{aligned} \$30 - \$9 &= t \\ t &= \$21 \end{aligned}$$

k represents the cost of each keychain

$$\begin{aligned} \$21 \div 7 &= k \\ k &= \$3 \end{aligned}$$

This time I choose to draw only one tape diagram and label both unknowns with letters. I know I first need to solve for t , and then I can solve for k . Labeling the unknowns with different letters helps me differentiate the two unknowns easily.

Each keychain costs \$3.

Now I can write my number sentences and a statement that answers the question.

G3-M7-Lesson 2

Kathy is 167 centimeters tall. The total height of Kathy and her younger sister Jenny is 319 centimeters. How much taller is Kathy than Jenny?
Draw at least 2 different ways to represent the problem.

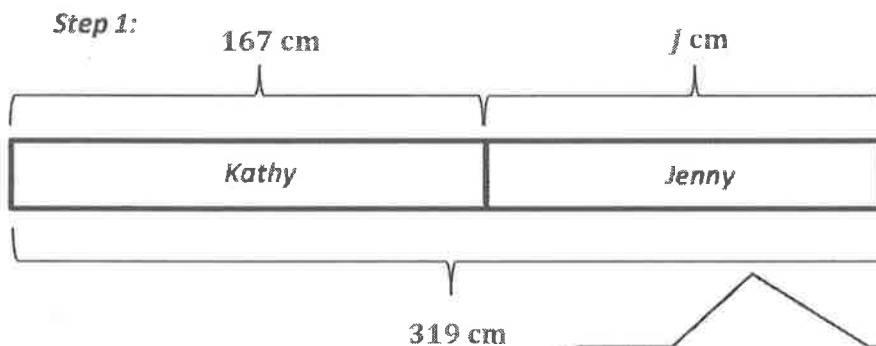

I can use the RDW process to help me solve. First, I need to read (and reread) the problem. This will help me visualize the problem. Then, I can draw a model to represent the problem with the known and unknown information.

j represents Jenny's height in centimeters

$$319 \text{ cm} - 167 \text{ cm} = j$$

$$j = 152 \text{ cm}$$

I notice that this is a two-step problem. From my drawing, I know the total height of the two sisters and the height of Kathy. The unknown in my drawing is Jenny's height, which is labeled with the letter *j*. I can write a subtraction equation to find her height. But this doesn't answer the question.

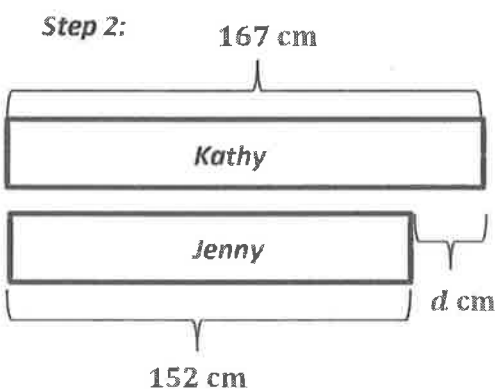

d represents the difference between the two heights in centimeters

$$167 \text{ cm} - 152 \text{ cm} = d$$

$$d = 15 \text{ cm}$$

The question is, "How much taller is Kathy than Jenny?" That means I need to draw a second diagram and write a subtraction equation to answer the question. I can label the unknown, which this time is the difference of their heights, with a new letter.

Finally, I can check my work when I write my statement.

Kathy is 15 centimeters taller than Jenny.

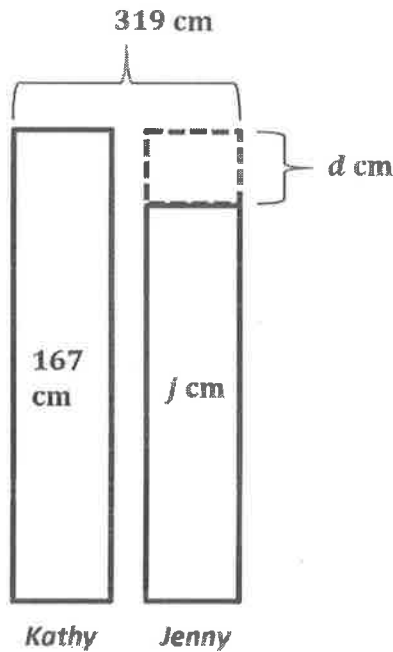

This is another way to represent the problem. I can draw my tape diagram vertically because the problem is about height. I can also put both unknowns in one diagram instead of drawing each step separately. This might save me time. The next step will be to write equations and a statement that go with my drawing.

Step 1:

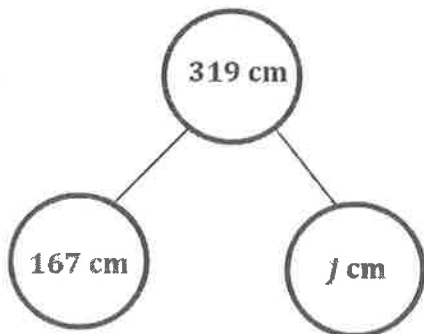

Step 2:

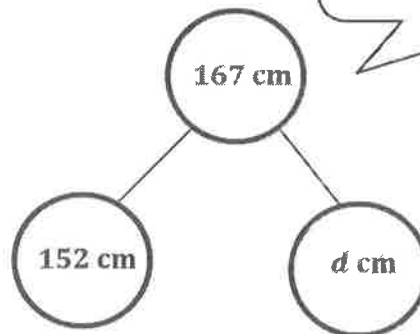

I could also model the problem using number bonds because they show the part-part-whole relationship.

There are many different ways to label and model the same problem, but I always want to draw a model that represents the problem most clearly to me. My drawing is important because it helps me decide on a way to solve, and it also helps me write my number sentences and a written statement to answer the question.

G3-M7-Lesson 3

Mrs. Yoon buys 6 bags of counters. Nine counters come in each bag. She gives each of her 12 math students 4 counters. How many counters does she have left?

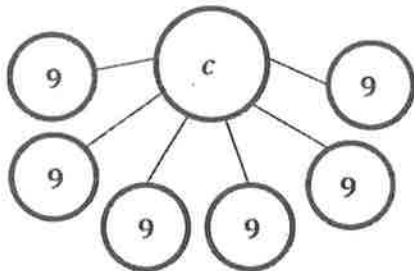

c represents the total number counters Mrs. Yoon buys.

$$\begin{aligned} 6 \times 9 &= c \\ c &= 54 \end{aligned}$$

Mrs. Yoon buys 54 counters.

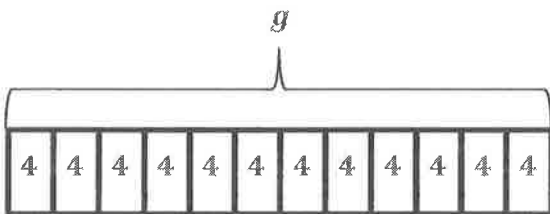

g represents the total number of counters Mrs. Yoon gives away.

$$\begin{aligned} g &= 12 \times 4 \\ &= (10 + 2) \times 4 \\ &= (10 \times 4) + (2 \times 4) \\ &= 40 + 8 \\ g &= 48 \end{aligned}$$

Mrs. Yoon gives away 48 counters.

$$54 - 48 = 6$$

Mrs. Yoon has 6 counters left.

I will use the RDW (Read-Draw-Write) process to solve this multi-step problem. First I'll read the problem, then I'll pause and visualize what's happening in the problem to get an idea about what to draw.

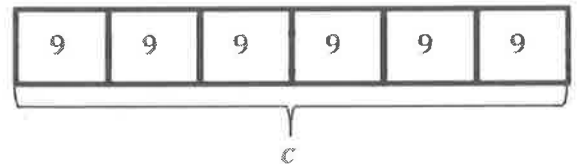

or

I can draw and label a picture of the problem in many different ways. Here's how I could use either a number bond or a tape diagram to show the first part of the problem. Both models show that the unknown is the whole, or the total.

Next, I can draw a second model to help me find the total number of counters Mrs. Yoon gives away. This time I can use g to represent the unknown.

To solve this larger fact I can break apart 12 as 10 and 2, then distribute the 4. I chose to break apart the 12 because tens facts are easy for me.

I can reread the question and see that my statement doesn't answer it. That helps me remember that there's one step left to do. I need to subtract the number of counters Mrs. Yoon gives away from her total counters to find how many she has left.

G3-M7-Lesson 4

1. Complete the chart by answering true or false.

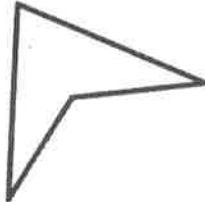
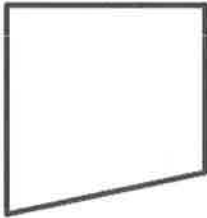
Attribute	Polygon	True or False
Example: 3 Sides		True
Quadrilateral		True
2 Sets of Parallel Sides		False

This is true. This shape has four sides and four angles. I know polygons with four straight sides and four angles are called quadrilaterals.

This is false. This shape only has 1 set of parallel sides. I can think of parallel sides like the two side lines of a capital H, or a slanted H, since not all parallel sides stand vertical. Even if the two lines go on forever, they will never cross.

2. Use a straightedge to sketch 2 different quadrilaterals with at least 1 set of parallel sides.

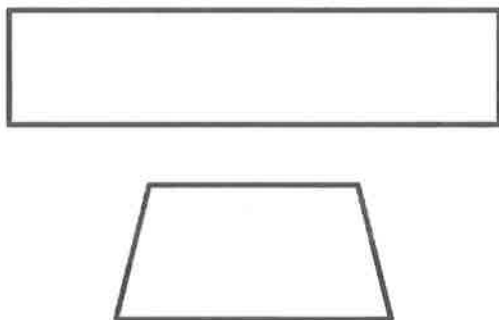

I can draw a rectangle with 2 sets of parallel sides and a trapezoid with 1 set of parallel sides.

G3-M7-Lesson 5

1. Match the polygons with their appropriate banners. A polygon can match to more than one banner.

Regular octagon

A polygon with all equal sides and all equal angles is called a regular polygon.

Pentagon

This pentagon has all equal sides. I can check using a ruler. But I know all the angles are not equal. It has 2 right angles, but the angle on the right is smaller than a right angle. So this pentagon can't be a regular pentagon.

Triangle

I notice that this triangle only matches one attribute. It does not have all equal sides or all equal angles. I can check by using a ruler and a right angle tool to measure the sides and angles. I also see that it does not have 1 right angle or parallel sides.

At least 1 set of parallel sides

All sides are equal.

At least 1 right angle

All sides are not equal.

2. Compare the two polygons below. What is the same? What is different?

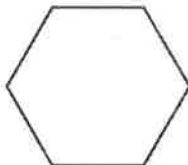
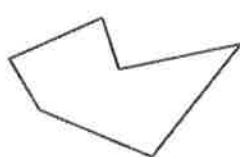

These polygons have the same name but look very different.

Both polygons have 6 sides, so they are both hexagons. The hexagon on the right is a regular hexagon because it has all equal sides and angles. The hexagon on the left does not have all equal sides and angles, so it is not a regular hexagon.

3. David draws the polygons below. Are any of them regular polygons? Explain how you know.

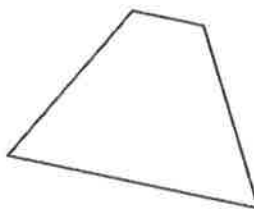
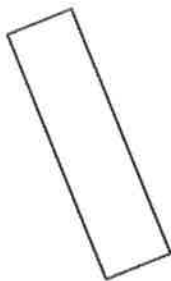
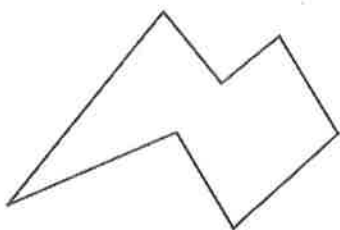

None of David's polygons are regular polygons. I know because I measured the sides and angles of each shape using my ruler and right angle tool, and none of these shapes have all equal sides and all equal angles.

My right angle tool is the corner of an index card. Using my measuring tools helps me to be precise.

G3-M7-Lesson 6

A right angle tool is just the corner of an index card.

Use a ruler and a right angle tool to help you draw the figures with the attributes given below.

1. Draw a triangle with all equal sides.

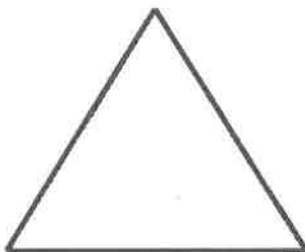

I can use my ruler to draw a triangle with three straight, equal sides. I don't have to worry about drawing any right angles because it doesn't have any.

2. Draw a quadrilateral with at least 1 set of parallel sides and at least 1 right angle. Mark the right angle and parallel sides.

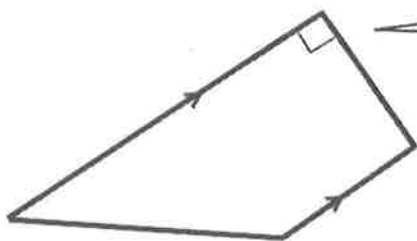

This square corner marks the right angle in my shape.

I notice shapes with more specific attributes are difficult to draw because I have to be more precise.

3. Melissa says she drew a polygon with 4 sides and 4 right angles with no parallel sides. Can Melissa be correct?

Melissa can't be correct because there is no quadrilateral with 4 right angles and no parallel sides. Only rectangles and squares have 4 sides and 4 right angles, but they both have 2 sets of parallel sides.

G3-M7-Lesson 7

The directions tell me the area of each square has to be 16 square units. I can figure out how many tetrominoes I will need by dividing, $16 \text{ square units} \div 4 \text{ square units} = 4$. I will need to use 4 tetrominoes for each square.

1. Use tetrominoes to create three squares, each with an area of 16 square units. Then, color the grid below to show how you created your squares. You may use the same tetromino more than once.

Tetrominoes

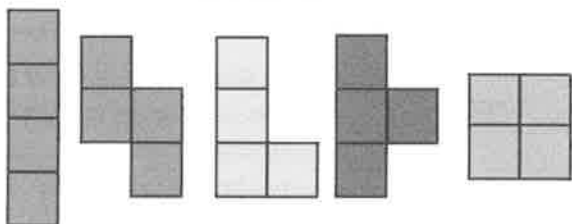

A tetromino is a shape that has an area of 4 square units, and each square unit shares a whole side with another square unit. This is a set of tetrominoes.

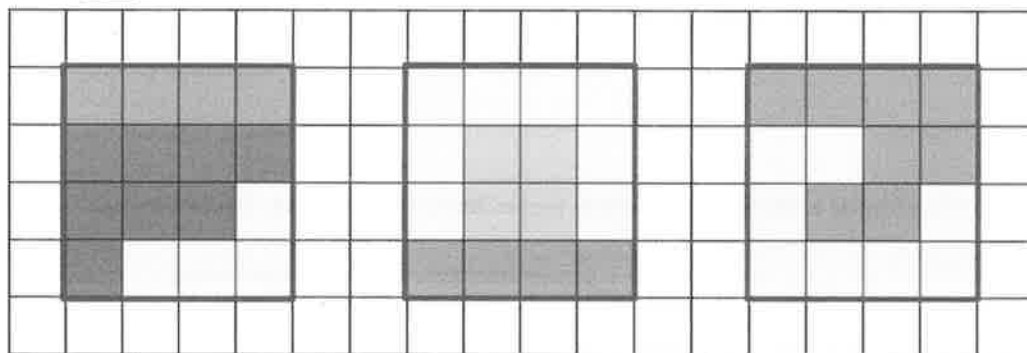

A strategy I can use to help me make a square with an area of 16 square units is by first marking a 4 by 4 square on the grid. This will help me make sure that my square has the right area. Then I can build the square with the tetrominoes. Sometimes I will need to rotate or flip my tetrominoes to build my shape.

I can check that my shapes are squares by counting the number of square units on each side and making sure they are all equal. I can also use my right angle tool to make sure that each shape has 4 right angles.

2. Explain how you know the area of each square is 16 square units.

I know the area of each square is 16 square units because I used 4 tetrominoes to make each square. Each tetromino has an area of 4 square units, and 4×4 square units = 16 square units.

- a. Write a number sentence to show the area of a square from Problem 1 as the sum of the areas of the tetrominoes you used to make the square.

Area: $4 \text{ square units} + 4 \text{ square units} + 4 \text{ square units} + 4 \text{ square units} = 16 \text{ square units}$

- b. Write a number sentence to show the area of a square above as the product of its side lengths.

Area: $4 \text{ units} \times 4 \text{ units} = 16 \text{ square units}$

I know side lengths are measured in length units, and area is labeled in square units.

The directions say to write a number sentence that shows the area of a square as the sum of the areas of the tetrominoes, so I know that each of my addends is labeled in square units.

G3-M7-Lesson 8

1. Draw a line to divide the rectangle below into 2 equal triangles.

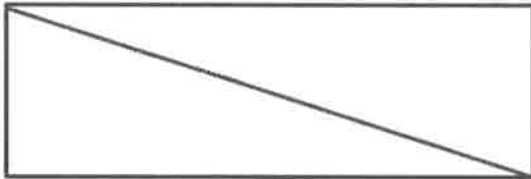

I can draw a diagonal line to divide the rectangle into 2 equal triangles.

2. Draw 2 lines to divide the quadrilateral below into 4 equal triangles.

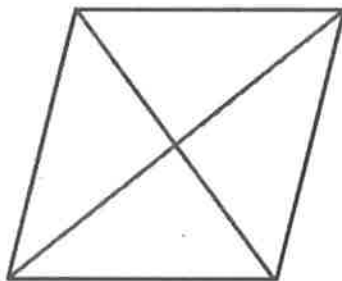

I can draw 2 diagonal lines to divide this quadrilateral into 4 equal triangles.

3. Choose three shapes from your tangram puzzle. Trace them below. Describe *at least* one attribute that they have in common.

A tangram is a special set of puzzle pieces with five triangles and two quadrilaterals that compose a square.

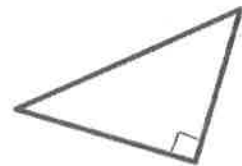
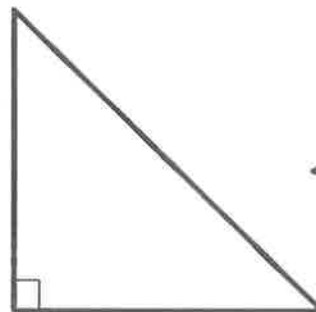
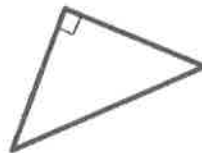

All three shapes are triangles. They all have 1 right angle and 3 sides. None of the triangles have parallel sides.

G3-M7-Lesson 9

1. Use your two smallest triangles to create a triangle, a parallelogram, and a square. Show how you created them below.

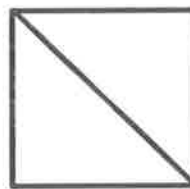
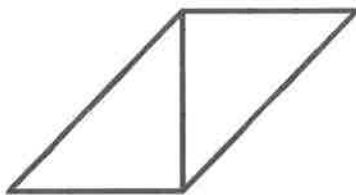
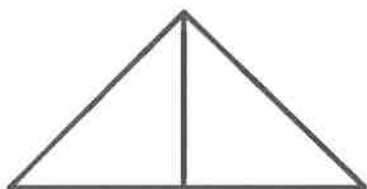

I know that when I make shapes with my tangram pieces, they cannot have any gaps or overlaps.

2. Use at least two tangram pieces to make and draw as many 4-sided polygons as you can. Draw lines to show where the tangram pieces meet.

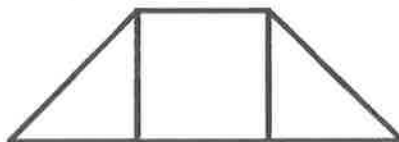
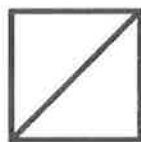

I can create all of these quadrilaterals using the 7 tangram pieces.

I know from an earlier lesson that each of these quadrilaterals can be decomposed into 2 triangles.

3. What attributes do your shapes in Problem 2 have in common? What attributes are different?

All of the shapes I made in Problem 2 are quadrilaterals because they have 4 sides. They all have at least 1 set of parallel lines and 4 angles. Not all of my shapes have equal sides or right angles. That's what makes them different.

G3-M7-Lesson 10

1. Trace the perimeter of the shapes below with a black crayon. Then shade in the areas with a blue crayon.

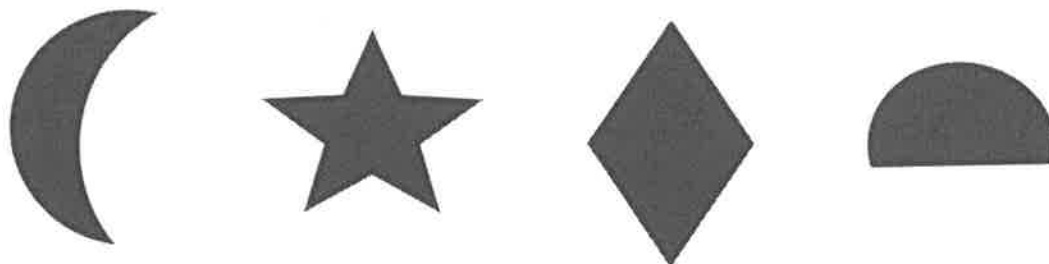

2. Explain how you know you traced the perimeters of the shapes above. How is the perimeter different from the area of a shape?

I know I traced the perimeters of the shapes because I traced the boundary of each shape with a black crayon, and the boundary is the perimeter. The area of a shape is different than the perimeter. Area measures the amount of space the shape takes up. I shaded the areas of the shapes in blue.

3. Explain how you could use a string to figure out which shape above has the greatest perimeter.

I can wrap string around each shape and mark where it touches the end after going all around the boundary of the shape. Then I can compare all of the marks, and the shape with the mark farthest from the end of the string has the greatest perimeter.

G3-M7-Lesson 11

1. Brian tessellates a parallelogram to make the shape below.

A tessellation is a figure made by copying a shape many times without any gaps or over laps.

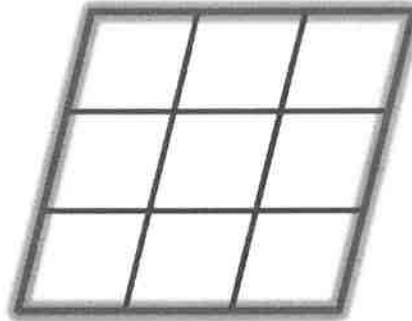

- a. Outline the perimeter of Brian's new shape with a highlighter.
- b. Name some attributes of his new shape.

Brian's new shape is a quadrilateral because it has 4 sides. It has 2 sets of parallel lines and 4 angles, but none of them are right angles. Brian created a large parallelogram from smaller parallelograms.

- c. Explain how Brian could use a string to measure the perimeter of his new shape.

Brian could wrap his string around the boundary of his shape and mark where the string touches its end. Then he could measure up to the mark on his string using a ruler.

- d. How could Brian increase the perimeter of his tessellation?

Brian could increase the perimeter of his tessellation by tessellating more shapes. If he tessellated another row or column of shapes, that would increase the perimeter.

I notice that the perimeter of the figure increases with each tessellation and decreases with taking away or erasing tessellations. I know that tessellations could go on forever, even past my paper!

2. Estimate to draw at least four copies of the given pentagon to make a new shape without gaps or overlaps. Outline the perimeter of your new shape with a highlighter.

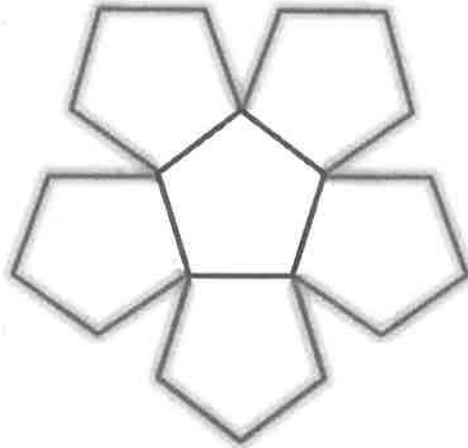
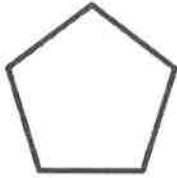

If my tessellations have overlaps or gaps, the shapes wouldn't fit together and the perimeter would not be accurate.

3. The marks on the strings below show the perimeters of Nancy's and Allen's shapes. Whose shape has a greater perimeter? How do you know?

Nancy's String:

Allen's String:

Nancy's shape has a greater perimeter. The mark on the string represents the perimeter of her shape, and it's farther down the string than Allen's mark.

It's just like how I compare numbers on the number line. I can pretend that the end of the string is like zero on the number line. Allen's mark is to the left of Nancy's, so Allen's is smaller because it is a shorter distance from 0.

G3-M7-Lesson 12

1. Measure and label the side lengths of the shapes below in centimeters. Then, find the perimeter of each shape.

a.

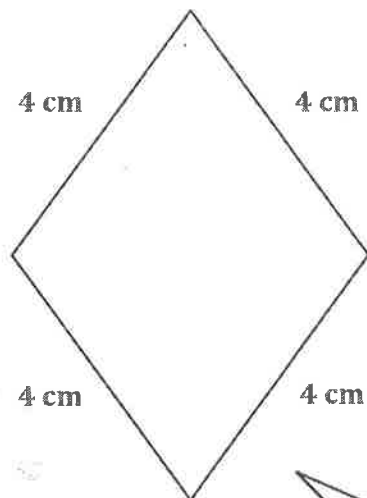

I know the sides of a shape form the boundary, or perimeter, of the shape. I can use a ruler to measure and label the side lengths of this shape in centimeters. Then I can add all of the side lengths together to find the perimeter.

$$\begin{aligned} \text{Perimeter} &= 4 \text{ cm} + 4 \text{ cm} + 4 \text{ cm} + 4 \text{ cm} \\ &= 16 \text{ cm} \end{aligned}$$

I notice this shape is a quadrilateral with 4 equal sides and no right angles. That means it's a rhombus!

I can also write this number sentence as $4 \times 4 \text{ cm} = 16 \text{ cm}$.

b.

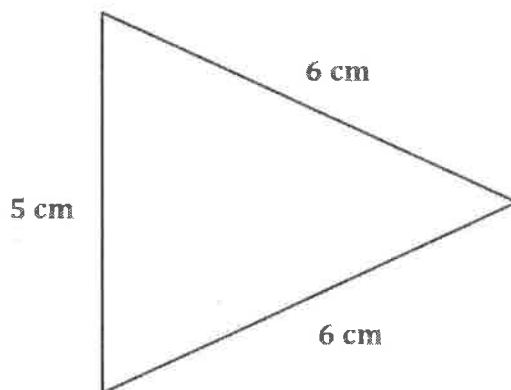

$$\begin{aligned} \text{Perimeter} &= 5 \text{ cm} + 6 \text{ cm} + 6 \text{ cm} \\ &= 17 \text{ cm} \end{aligned}$$

It's important to label all of my measurements with the correct unit.

2. Albert measures the two side lengths of the rectangle shown below. He says he can find the perimeter with the measurements. Explain Albert's thinking. Then, find the perimeter in centimeters.

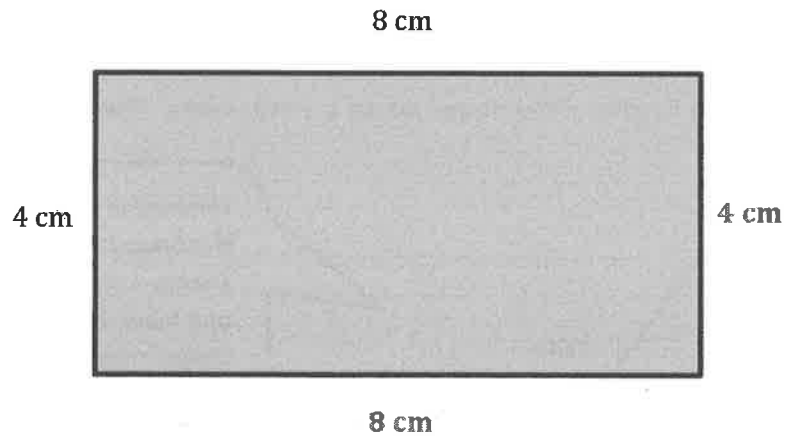

Albert can find the perimeter using the two side lengths he measured because opposite sides of a rectangle are equal. Since he knows the lengths of the two sides, he knows the lengths of the other two sides. Now he can find the perimeter.

$$\begin{aligned}\text{Perimeter} &= 4 \text{ cm} + 8 \text{ cm} + 4 \text{ cm} + 8 \text{ cm} \\ &= 24 \text{ cm}\end{aligned}$$

I can also think of this problem as 3 eights = 24, or 12 + 12 = 24.

The perimeter of the rectangle is 24 centimeters.

G3-M7-Lesson 13

1. Find the perimeter of the following shapes.

a.

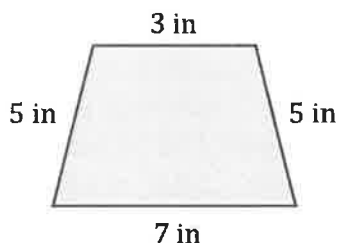

I see that the side lengths of each shape are already given, so I do not need to measure them. Now I just need to add the side lengths to find the perimeter.

$$P = 3 \text{ in} + 5 \text{ in} + 5 \text{ in} + 7 \text{ in}$$

$$P = 20 \text{ in}$$

This quadrilateral has 1 set of parallel lines and no right angles. It's a trapezoid.

b.

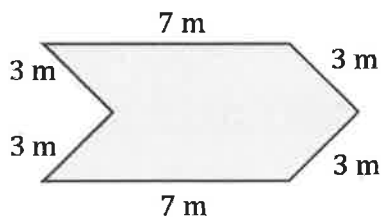

$$P = 3 \text{ m} + 3 \text{ m} + 7 \text{ m} + 3 \text{ m} + 7 \text{ m} + 3 \text{ m}$$

$$P = 26 \text{ m}$$

This shape has six sides, so it's a hexagon. It is not a regular hexagon because it does not have all equal sides.

I notice that each shape uses different units to measure. I need to make sure to label my measurements and their units correctly.

2. Allyson's rectangular garden is 31 feet long and 49 feet wide. What is the perimeter of Allyson's garden?

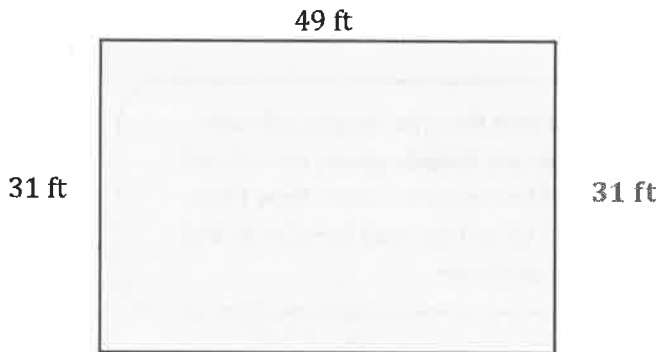

I know the lengths of the other two sides because opposite sides of a rectangle are equal.

$$P = 31 \text{ ft} + 49 \text{ ft} + 31 \text{ ft} + 49 \text{ ft}$$

$$P = 160 \text{ ft}$$

I can use mental math to solve. I think of this problem as $30 \text{ ft} + 50 \text{ ft} + 30 \text{ ft} + 50 \text{ ft}$ since 1 less than 31 is 30 and 1 more than 49 is 50. $50 \text{ ft} + 50 \text{ ft} = 100 \text{ ft}$. Then, I just need to add 60 ft more because $30 \text{ ft} + 30 \text{ ft} = 60 \text{ ft}$.

The perimeter of Allyson's garden is 160 feet.

G3-M7-Lesson 14

1. Label the unknown side lengths of the regular shapes below. Then, find the perimeter of each shape.

a.

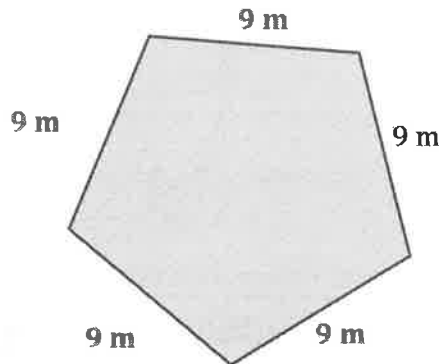

$$\text{Perimeter} = 5 \times 9 \text{ m} = 45 \text{ m}$$

Since this shape is a regular pentagon, I know that all the side lengths are equal. So each of the 5 sides measures 9 m.

I can write a repeated addition sentence to find the perimeter, but a multiplication sentence is more efficient. I can write $5 \times 9 \text{ m}$. 5 represents the number of sides, and 9 m is the length of each side.

b.

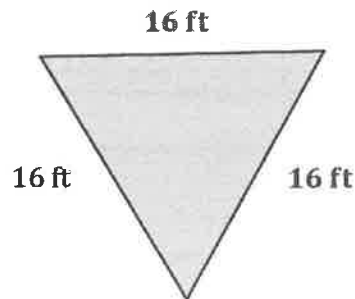

$$\begin{aligned} \text{Perimeter} &= 3 \times 16 \text{ ft} \\ &= (3 \times 10 \text{ ft}) + (3 \times 6 \text{ ft}) \\ &= 30 \text{ ft} + 18 \text{ ft} \\ &= 48 \text{ ft} \end{aligned}$$

I can use the break apart and distribute strategy to solve for a large fact like $3 \times 16 \text{ ft}$. I can break apart 16 ft as 10 ft and 6 ft since multiplying by tens is easy. Then I can add the two smaller facts to find the answer to the larger fact.

2. Jake traces a regular octagon on his paper. Each side measures 6 centimeters. He also traces a regular decagon on his paper. Each side of the decagon measures 4 centimeters. Which shape has a greater perimeter? Show your work.

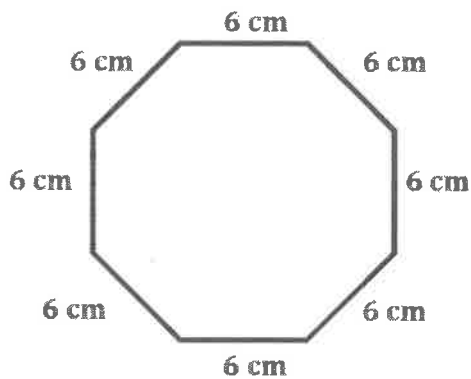

$$\text{Perimeter} = 8 \times 6 \text{ cm} = 48 \text{ cm}$$

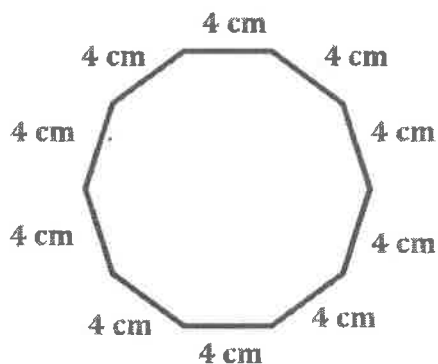

$$\text{Perimeter} = 10 \times 4 \text{ cm} = 40 \text{ cm}$$

Jake's octagon has a greater perimeter by 8 cm.

Even though a decagon has more sides than an octagon, the side lengths of Jake's octagon are longer than the side lengths of his decagon. That's why Jake's octagon has a greater perimeter.

G3-M7-Lesson 15

1. Mr. Kim builds a 7 ft by 9 ft rectangular fence around his vegetable garden. What is the total length of Mr. Kim's fence?

I know that I need to draw and label a rectangle to represent Mr. Kim's fence. I can label all the side lengths of my rectangle because I know that opposite sides of a rectangle are equal.

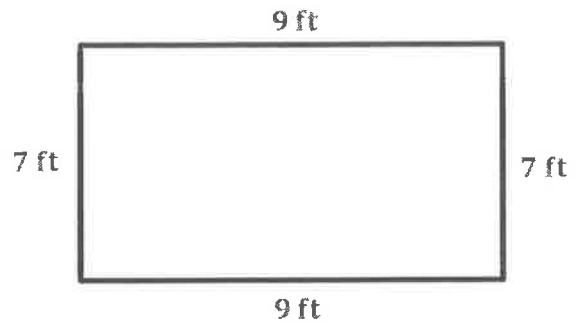

There are different strategies to find the perimeter of this rectangle. I could add 7 and 9 and then double the sum, or I can multiply each side length by 2 and then add the products just like I did here.

$$\begin{aligned} P &= (2 \times 7 \text{ ft}) + (2 \times 9 \text{ ft}) \\ &= 14 \text{ ft} + 18 \text{ ft} \\ &= 32 \text{ ft} \end{aligned}$$

The total length of Mr. Kim's fence is 32 feet.

2. Gracie uses regular triangles to make the shape below. Each side length of a triangle measures 4 cm. What is the perimeter of Gracie's shape?

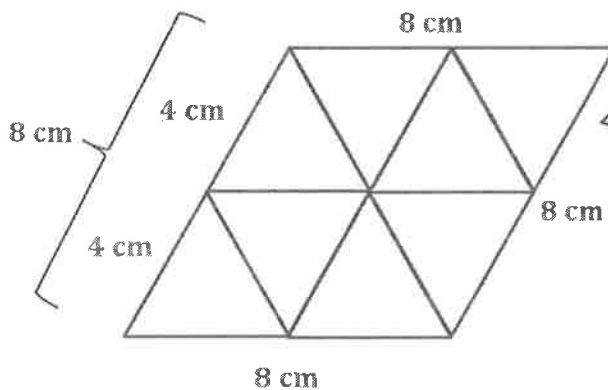

$$P = 4 \times 8 \text{ cm} = 32 \text{ cm}$$

The perimeter of Gracie's shape is 32 cm.

I know that each side length of the regular triangle is 4 cm. Since each side length of Gracie's larger shape is made up of 2 sides of a triangle, the side length of the larger shape is 8 cm. Now I can find the perimeter of her shape by writing a repeated addition sentence or multiplying the 4 side lengths by 8 cm.

Gracie's new shape has 4 equal sides and no right angles. It's a rhombus!

G3-M7-Lesson 16

1. Alicia draws the shape below.



I know shapes that don't have straight lines, like circles, still have a perimeter. But I can't just use rulers to find their perimeters. I can estimate by using a string to represent the perimeter and then measure the string.

- a. Explain how Alicia could use string and a ruler to find the shape's perimeter.

Alicia can wrap string around the boundary of her shape. Then, she can mark where the string meets the end after going all the way around once. Finally, she can use a ruler to measure from the end of the string to the mark.

I know this method does not give me an exact perimeter since I am using string. It is a close estimate.

- b. Would you use this method to find the perimeter of a rectangle? Explain why or why not.

I would not use this method to find the perimeter of a rectangle. Using string is not as efficient or as precise as measuring the sides of a rectangle with a ruler and then adding the side lengths together.

2. Can you find the perimeter of the shape below using just your ruler? Explain your answer.

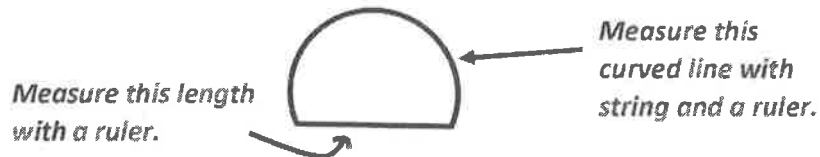

No, I can't find the perimeter of the shape using just my ruler. The boundary of the shape has a curved line, and I can't measure curved lines with just a ruler. I can measure the straight side length with a ruler and use string to measure the curved line. Then, I can add the two measurements together to find the perimeter.

G3-M7-Lesson 17

1. The shape below is made up of rectangles. Label the unknown side lengths. Then, write and solve an equation to find the perimeter of the shape.

This is one way I can visualize how two rectangles fit together to make this shape.

I can find this unknown side length by adding the known widths, 3 cm and 2 cm, to get 5 cm. This whole side length is 5 cm.

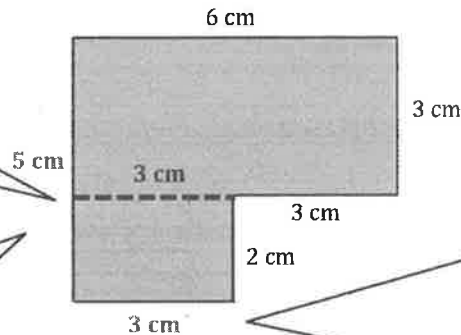

If I extended the line on the bottom to match the one at the top, it would be 6 cm because opposite sides of a rectangle are equal. Knowing that, I can subtract the part labeled 3 cm to find the length of the bottom line.

$$\begin{aligned} P &= (3 \times 3 \text{ cm}) + 2 \text{ cm} + 5 \text{ cm} + 6 \text{ cm} \\ &= 9 \text{ cm} + 13 \text{ cm} \\ &= 22 \text{ cm} \end{aligned}$$

Now that I know the unknown side lengths of the shape, I can find the perimeter.

The perimeter of the shape is 22 cm

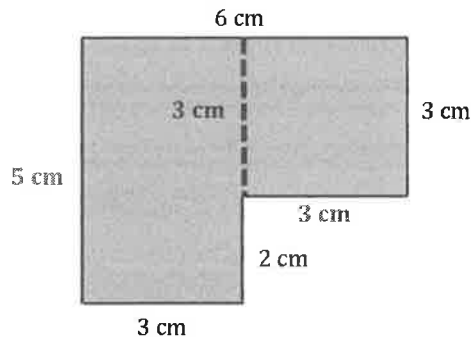

This is another way I can visualize how two rectangles fit together to make this shape. This time I see one rectangle and one square.

2. Label the unknown side lengths. Then, find the perimeter of the shaded rectangle.

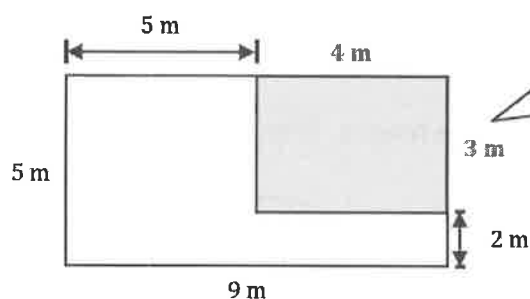

I know the side lengths of the whole rectangle are 9 m and 5 m. In order to find the side lengths of the shaded part, I can subtract the total lengths from the known parts.
 $9\text{ m} - 5\text{ m} = 4\text{ m}$, and $5\text{ m} - 2\text{ m} = 3\text{ m}$.

$$\begin{aligned} P &= (2 \times 4\text{ cm}) + (2 \times 3\text{ cm}) \\ &= 8\text{ cm} + 6\text{ cm} \\ &= 14\text{ cm} \end{aligned}$$

The perimeter of the shaded rectangle is 14 cm.

Now that I know the side lengths of the shaded part, I can find the perimeter. I know from the question that the shaded part is a rectangle. So its opposite sides are equal.

G3-M7-Lesson 18

Estimate to draw as many rectangles as you can with an area of 15 square centimeters. Label the side lengths of each rectangle.

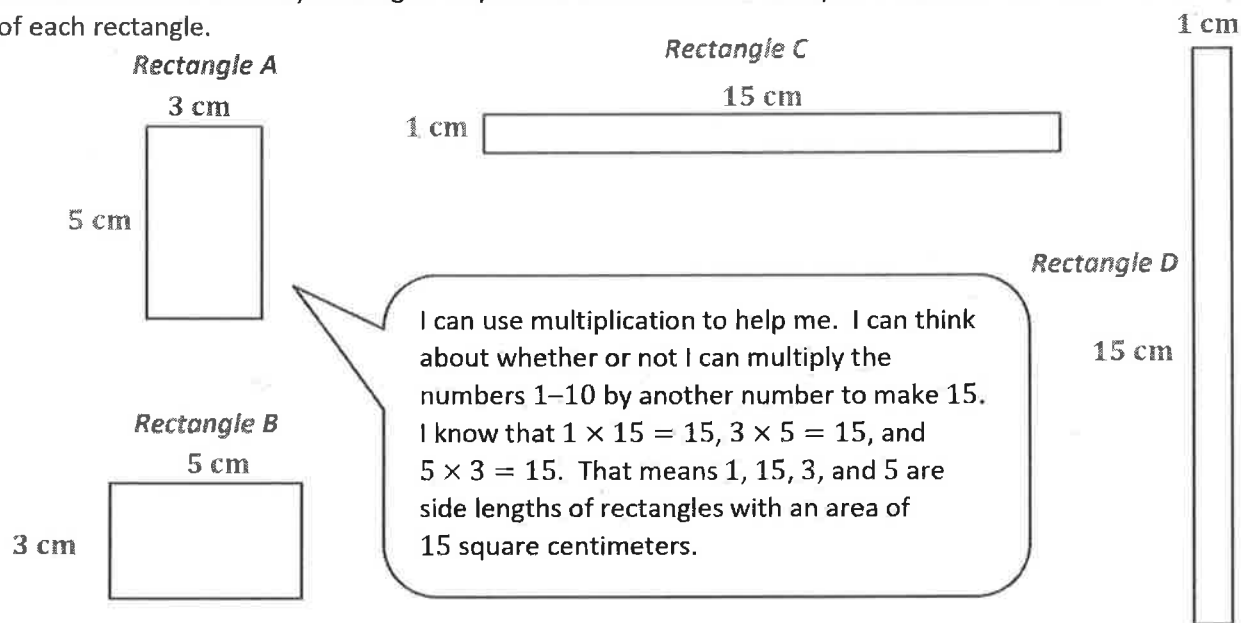

- a. Which rectangles above have the greatest perimeter? How do you know just by looking at their shape?

Rectangles C and D have the greatest perimeter. They both have a perimeter of 32 centimeters. I can tell just by looking at their shapes that they have the greatest perimeter because they are longer and skinnier than Rectangles A and B.

I know that long, skinny rectangles have larger perimeters than short, wide rectangles with the same area. Long side lengths add up to greater perimeters than short side lengths.

- b. Which rectangles above have the smallest perimeter? How do you know just by looking at their shape?

Rectangles A and B have the smallest perimeter. They both have a perimeter of 16 centimeters. I can tell just by looking at their shapes that they have the smallest perimeter because they are shorter and wider than Rectangles C and D.

I know that short, wide rectangles have smaller perimeters than long, skinny rectangles with the same area. Short side lengths add up to smaller perimeters than long side lengths.

G3-M7-Lesson 19

1. Use unit squares to make rectangles for each given number below. Complete the charts to show how many rectangles you can make for each given number of unit squares. You might not use all the spaces in each chart.

Number of unit squares = 12	
Number of rectangles I made: <u>3</u>	
Width	Length
1	12
2	6
3	4

Number of unit squares = 13	
Number of rectangles I made: <u>1</u>	
Width	Length
1	13

Number of unit squares = 14	
Number of rectangles I made: <u>2</u>	
Width	Length
1	14
2	7

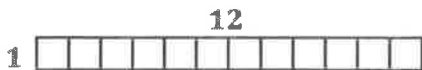
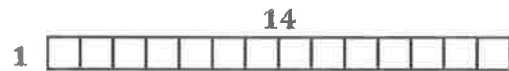
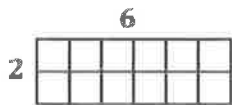
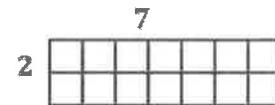
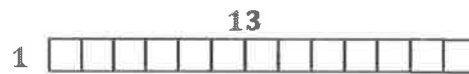
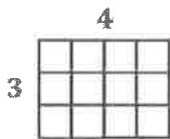

I can use multiplication to help me. I can think about whether or not I can multiply the numbers 1–10 by another number to make 12, 13, or 14. Once I figure out factors that equal those numbers when multiplied, I can build rectangles with the factors as the side lengths.

2. Create a line plot with the data you collected in Problem 1.

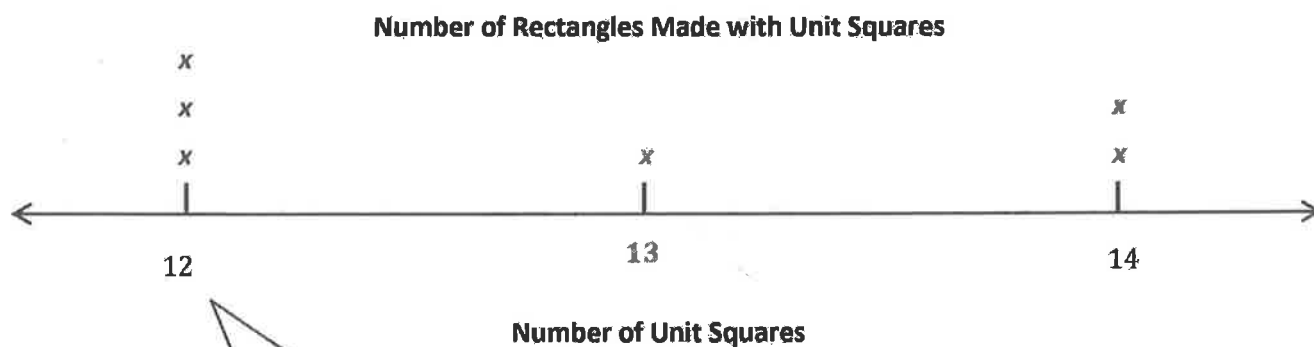

I made 3 rectangles with an area of 12 square units, so I'll draw 3 x's above the 12. I can keep going to show how many rectangles I made with 13 and 14 square units.

G3-M7-Lesson 20

1. Rex uses unit square tiles to make rectangles with a perimeter of 12 units. He draws his rectangles as shown below. Can Rex make another rectangle using unit square tiles that has a perimeter of 12 units? Explain your answer.

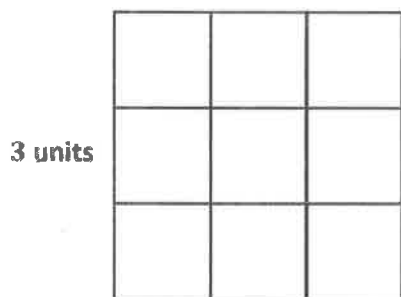
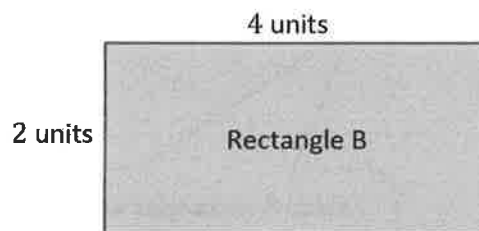
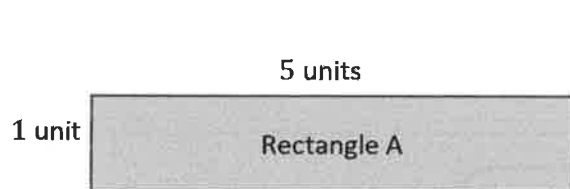

Yes. Rex can also make a square with each side measuring 3 units. Squares are also rectangles. To find the perimeter, I would add $3 + 3 + 3 + 3 = 12$.

The addition double for 12 is $6 + 6$. In Rectangle A, I split the 6 apart into side lengths of 5 and 1. In Rectangle B, I split the 6 apart into side lengths of 4 and 2. I can still split the 6 up another way: 3 and 3.

2. Maureen draws a square that has a perimeter of 24 centimeters.
- a. Estimate to draw Maureen's square below. Label the length and width of the square.

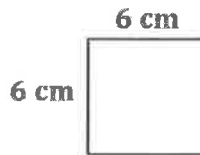

$$6 + 6 + 6 + 6 = 24$$

$$4 \times 6 = 24$$

To figure out the side lengths, I think "4 times what equals 24"? I know that $4 \times 6 = 24$, so each side is 6 centimeters.

- b. Find the area of Maureen's square.

$$6 \times 6 = 36$$

The area of Maureen's square is 36 square centimeters.

I can multiply the side lengths to find the area.

- c. Estimate to draw a different rectangle that has the same perimeter as Maureen's square.

Sample response:

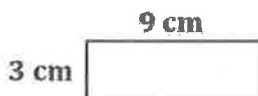

$$9 + 3 + 9 + 3 = 24$$

The addition double for 24 is $12 + 12$. Another pair of numbers that adds up to 12 is 9 and 3.

- d. Which shape has a greater area, Maureen's square or your rectangle?

$$3 \times 9 = 27$$

My rectangle has an area of 27 square centimeters. Maureen's square has a greater area because $36 > 27$.

I can multiply 3×9 to find the area of my rectangle and then compare it to the area of Maureen's square.

G3-M7-Lesson 21

1. Max uses unit squares to build rectangles that have a perimeter of 12 units. He creates the chart below to record his findings.

- a. Complete Max's chart. You might not use all the spaces in the chart.

Perimeter = 12 units		
Number of rectangles I made: <u>3</u>		
Width	Length	Area
1 unit	5 units	5 square units
2 units	4 units	8 square units
3 units	3 units	9 square units

For a perimeter of 12 units, the total of all four side lengths has to be 12 units. I can think about the addition double for 12, which is $6 + 6$. That tells me that 6 units should be the sum of the length plus the width. I can find the same information by thinking about $12 \div 2$.

To draw my rectangles, I think about pairs of numbers that equal 6 when I add them. The pairs I use to draw my rectangles are 1 and 5, 2 and 4, and 3 and 3. Then, to find the area of each rectangle, I multiply the side lengths. $1 \times 5 = 5$, $2 \times 4 = 8$, and $3 \times 3 = 9$. Now I can complete the chart.

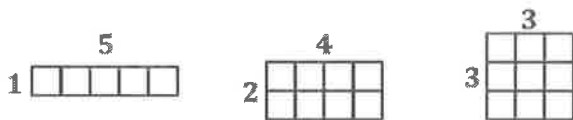

- b. Explain how you found the widths and lengths in the chart above.

I know that half of 12 is 6 because $6 + 6 = 12$. I thought about different ways to break apart 6. One way to break 6 apart is into 5 and 1. So, one rectangle can have side lengths of 5 units and 1 unit. Another way is 4 and 2. The last way to break apart 6 is 3 and 3. Those numbers became my side lengths.

2. Grayson and Scarlett both draw rectangles with perimeters of 10 centimeters, but their rectangles have different areas. Explain with words, pictures, and numbers how this is possible.

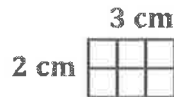
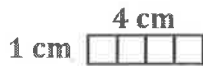
Grayson's Rectangle*Scarlett's Rectangle*

First I can think of 2 different ways to make a rectangle with a perimeter of 10 centimeters. Then, I can multiply their side lengths to find the area of each.

Grayson's and Scarlett's rectangles each have a perimeter of 10 centimeters. But the side lengths of their rectangles are different. That's what makes the product of the side lengths different, even though the sum is the same. The area of Grayson's rectangle is 6 square centimeters because $2 \times 3 = 6$. The area of Scarlett's rectangle is 4 square centimeters because $1 \times 4 = 4$.

G3-M7-Lesson 22

1. Jack uses square inch tiles to build a rectangle with a perimeter of 14 inches. Does knowing this help him find the number of rectangles he can build with an area of 14 square inches? Why or why not?

No, it doesn't. There is no connection between area and perimeter, so knowing how to build a rectangle with a perimeter of 14 inches doesn't help Jack figure out how many rectangles he can build with an area of 14 square inches.

I've studied area and perimeter a lot in class, and I know that they aren't related. If I want to know how many rectangles I can build with an area of 14 square inches, I can use square tiles or multiplication to figure it out. Thinking about perimeter won't help me.

2. Rachel makes a rectangle with a piece of string. She says the perimeter of her rectangle is 25 centimeters. Explain how it's possible for her rectangle's perimeter to be an odd number.

Most of the rectangles we've seen had an even perimeter because we usually look at rectangles with whole number side lengths. Rectangles can have odd perimeters if their side lengths are not whole numbers.

I know that rectangles with whole number side lengths have even perimeters because when you double the sum of whole numbers, you get an even number. Rectangles with fractional side lengths can have odd perimeters if the fractional parts add up to an odd number. For example, if a square has a side length of $\frac{1}{4}$, then the perimeter equals 1 because four copies of $\frac{1}{4}$ makes 1.

G3-M7-Lesson 23

1. Madison uses 4-inch square tiles to make a rectangle, as shown below. What is the perimeter of the rectangle in inches?

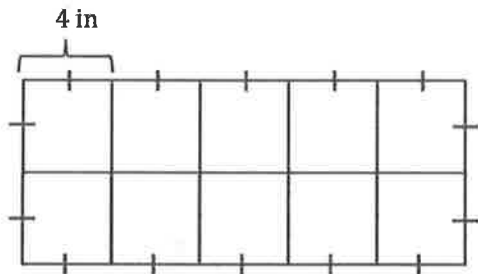

$$\begin{aligned}
 P &= 14 \text{ fours} \\
 &= 10 \text{ fours} + 4 \text{ fours} \\
 &= 40 + 16 \\
 &= 56
 \end{aligned}$$

Since Madison uses square tiles, I know that each side length of a tile measures 4 inches. I can then count the total number of side lengths that make up the perimeter of the rectangle, which is 14. Then I can find the perimeter by multiplying 14×4 , or in unit form, 14 fours. I can use the break apart and distribute strategy to find the total.

I can also break up 14 fours as 7 fours + 7 fours, but $28 + 28$ is harder mental math than $40 + 16$.

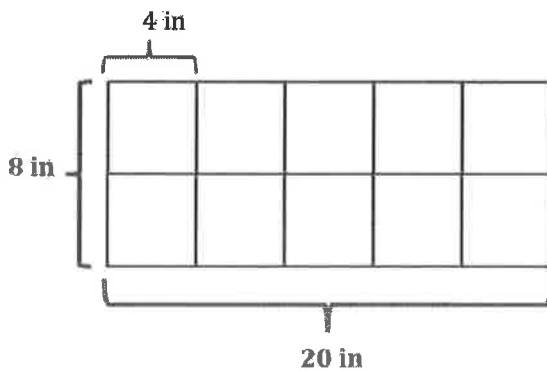

$$\begin{aligned}
 P &= (2 \times 8 \text{ in}) + (2 \times 20 \text{ in}) \\
 &= 16 \text{ in} + 40 \text{ in} \\
 &= 56 \text{ in}
 \end{aligned}$$

Another way to find the perimeter is to find the value of the rectangle's side lengths. I can use repeated addition, skip-counting, or multiplication to find the side lengths. Then, I can double each side length and add to find the perimeter.

The perimeter of the rectangle is 56 inches.

2. David traces 4 regular hexagons to create the shape shown below. The perimeter of 1 hexagon is 18 cm. What is the perimeter of David's new shape?



$$\begin{aligned} \text{Perimeter of 1 hexagon} &= 18 \text{ cm} \div 6 \\ &= 3 \text{ cm} \end{aligned}$$

$$\begin{aligned} \text{Perimeter of the shape} &= 18 \times 3 \text{ cm} \\ &= (10 \times 3 \text{ cm}) + (8 \times 3 \text{ cm}) \\ &= 30 \text{ cm} + 24 \text{ cm} \\ &= 54 \text{ cm} \end{aligned}$$

The perimeter of the shape is 54 cm.

This is a two-step problem. First I need to find the side length of each hexagon. I know David traces regular hexagons, so all of the side lengths are equal. To find the side length, I can divide the perimeter of 1 hexagon, 18 cm, by its 6 sides to get 3 cm.

Next, I can count to find the total number of sides on David's new shape. I can't just multiply 4×6 to get the total number of sides because each hexagon shares 1 or 2 sides with another hexagon. I can mark the sides to help me count them. David's new shape has 18 sides. Now I can multiply 18 by 3 cm to get the perimeter of the shape.

G3-M7-Lesson 24

1. Robin draws a square with a perimeter of 36 inches. What is the width and length of the square?

$$36 \div 4 = 9$$

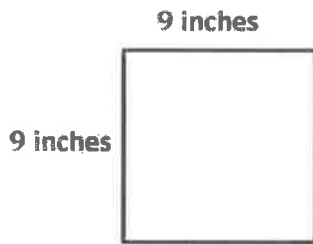

I know that all 4 sides of a square are the same length. I can divide the perimeter by 4 to find the width and length of Robin's square.

The width and length of Robin's square are each 9 inches.

2. A rectangle has a perimeter of 16 centimeters.
- a. Estimate to draw as many different rectangles as you can that have a perimeter of 16 centimeters. Label the width and length of each rectangle.

$$16 \div 2 = 8$$

$$1 + 7 = 8 \quad w = 1, l = 7$$

$$2 + 6 = 8 \quad w = 2, l = 6$$

$$3 + 5 = 8 \quad w = 3, l = 5$$

$$4 + 4 = 8 \quad w = 4, l = 4$$

I can divide the perimeter by 2 and then find pairs of numbers that have a sum of 8.

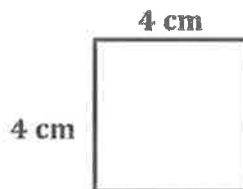
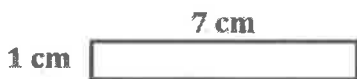

I can estimate to draw the 4 rectangles that I found.

- b. Explain the strategy you used to find the rectangles.

I divided the perimeter by 2, so $16 \div 2 = 8$. Then I found pairs of numbers that have a sum of 8. The pairs of numbers that have sums of 8 give me possible whole number side lengths for rectangles with a perimeter of 16 centimeters.

I can divide the perimeter by 2 because the perimeter of a rectangle can be found by adding the width and the length and then multiplying by 2.

$$\text{Perimeter} = 2 \times (\text{width} + \text{length})$$

$$\text{Perimeter} \div 2 = \text{width} + \text{length}$$

G3-M7-Lesson 25

The house below is made of rectangles and 1 triangle. The side lengths of each rectangle are labeled. Find the perimeter of each rectangle, and record it in the table on the next page.

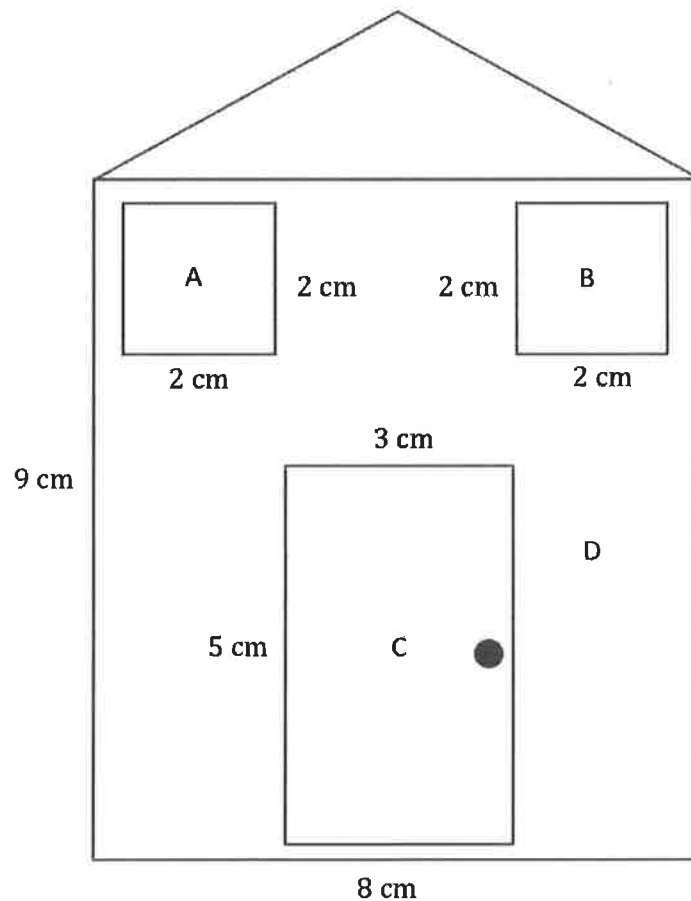

I can see 4 rectangles: the 2 windows, the door, and the outline of the house.

Rectangle	Perimeter
A	$4 \times 2 \text{ cm} = 8 \text{ cm}$ Perimeter = 8 cm
B	$4 \times 2 \text{ cm} = 8 \text{ cm}$ Perimeter = 8 cm
C	$5 \text{ cm} + 5 \text{ cm} + 3 \text{ cm} + 3 \text{ cm} = 16 \text{ cm}$ Perimeter = 16 cm
D	$8 \text{ cm} + 8 \text{ cm} + 9 \text{ cm} + 9 \text{ cm} = 34 \text{ cm}$ Perimeter = 34 cm

Rectangles A and B are squares, so I can find the perimeters by multiplying 4×2 .

Another strategy I can use to find each perimeter is to add the width and length of the rectangle and then multiply the sum by 2. For Rectangle C, that would look like this:

$$P = 2 \times (5 + 3)$$

$$P = 2 \times 8$$

$$P = 16$$

G3-M7-Lesson 26

Each student in Mrs. William's class draws a rectangle with whole number side lengths and a perimeter of 32 centimeters. Then, they find the area of each rectangle and create the table below.

Area in Square Centimeters	Number of Students
15	1
28	2
39	2
48	3
55	4
60	6
63	2
64	2

I know there can be many different areas for rectangles with the same perimeter.

- a. What does this chart tell you about the relationship between area and perimeter?

The chart shows 8 different areas for rectangles with the same perimeter. So, I know that area and perimeter are 2 separate things. There's no connection between them.

- b. Did any students in Mrs. William's class draw a square? Explain how you know.

Yes, 2 students drew a square. I know because I found all the possible side lengths of rectangles with a perimeter of 32 cm, and one rectangle has all equal side lengths of 8 cm. A square with side lengths of 8 cm has an area of 64 sq cm. On the chart, it shows that 2 students drew a rectangle with an area of 64 square centimeters.

Perimeter is double the sum of the width and length of a rectangle. To find the side lengths of a rectangle with a perimeter of 32, I'll start by dividing the perimeter by 2 to get 16. Then, I can find pairs of numbers that add up to 16. Those are the possible side lengths.

- c. What are the side lengths of the rectangle that most students in Mrs. William's class made?

I see that most students drew a rectangle with an area of 60 square centimeters. The side lengths of this rectangle are 6 cm and 10 cm.

G3-M7-Lesson 27

Record the perimeters and areas of the rectangles in the chart on the next page.

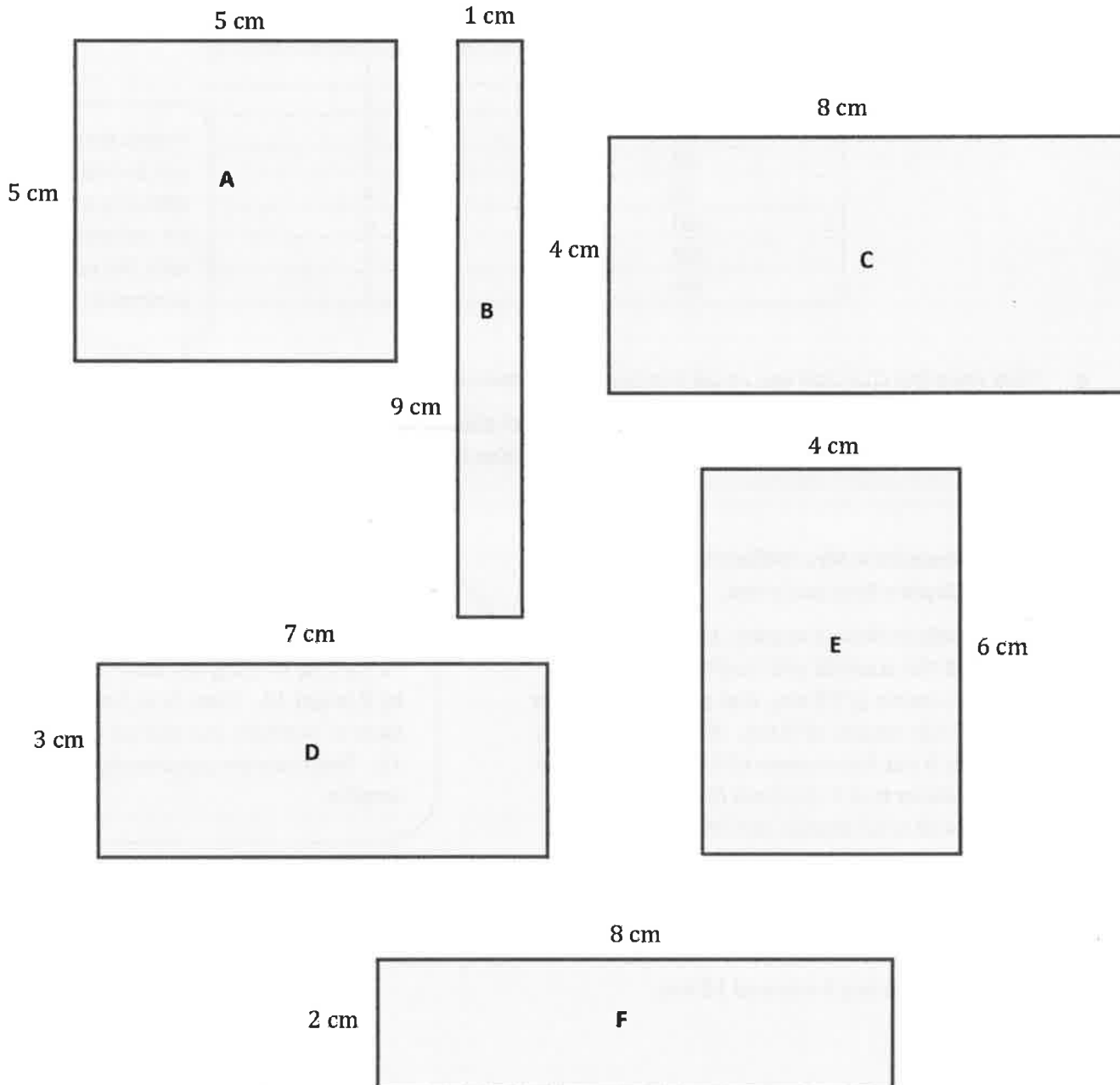

I can choose to use mental math to solve for the perimeter and area. I do not need to write out multiplication and addition sentences if I can do it in my head.

1. Find the area and perimeter of each rectangle.

Rectangle	Width and Length	Perimeter	Area
A	<u>5</u> cm by <u>5</u> cm	$4 \times 5 \text{ cm} = 20 \text{ cm}$	$5 \text{ cm} \times 5 \text{ cm} = 25 \text{ sq cm}$
B	<u>9</u> cm by <u>1</u> cm	$18 \text{ cm} + 2 \text{ cm} = 20 \text{ cm}$	$9 \text{ cm} \times 1 \text{ cm} = 9 \text{ sq cm}$
C	<u>4</u> cm by <u>8</u> cm	$8 \text{ cm} + 16 \text{ cm} = 20 \text{ cm}$	$4 \text{ cm} \times 8 \text{ cm} = 32 \text{ sq cm}$
D	<u>3</u> cm by <u>7</u> cm	$6 \text{ cm} + 14 \text{ cm} = 20 \text{ cm}$	$3 \text{ cm} \times 7 \text{ cm} = 21 \text{ sq cm}$
E	<u>6</u> cm by <u>4</u> cm	$12 \text{ cm} + 8 \text{ cm} = 20 \text{ cm}$	$6 \text{ cm} \times 4 \text{ cm} = 24 \text{ sq cm}$
F	<u>2</u> cm by <u>8</u> cm	$4 \text{ cm} + 16 \text{ cm} = 20 \text{ cm}$	$2 \text{ cm} \times 8 \text{ cm} = 16 \text{ sq cm}$

2. What do you notice about the perimeters of all the rectangles?

All of the rectangles have different side lengths but the same perimeter of 20 cm.

I can see again how perimeter and area do not have any connection with one another.

3. Which rectangle is a square? How do you know?

Rectangle A is a square. I know because the width and length have the same measurement. Since opposite sides of rectangles are equal, Rectangle A has all equal side lengths and 4 right angles. That means it's a square!

G3-M7-Lesson 28

A square sheet of construction paper has side lengths of 9 inches.

- a. Estimate to draw the square sheet of paper, and label the side lengths.

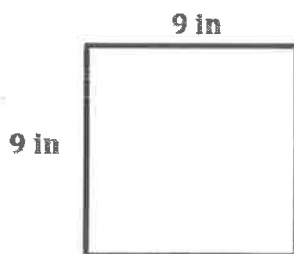

I know that the side lengths of a square are equal.

- b. What is the area of the square paper?

$$\begin{aligned} A &= 9 \text{ in} \times 9 \text{ in} \\ &= 81 \text{ sq in} \end{aligned}$$

The area of the paper is 81 square inches.

I found the answer to 9×9 using a tens fact and mental math. I thought about the problem as $9 \times 10 = 90$, and $90 - 9 = 81$.

- c. What is the perimeter of the square paper?

$$\begin{aligned} P &= 4 \times 9 \text{ in} \\ &= 36 \text{ in} \end{aligned}$$

The perimeter of the square paper is 36 inches.

I chose to write a multiplication sentence instead of a repeated addition sentence because it is more efficient. I can also think of this problem as $4 \times 10 = 40$, and $40 - 4 = 36$.

- d. Caitlyn connects three of these square papers to make one long banner. What is the perimeter of the new rectangular banner?

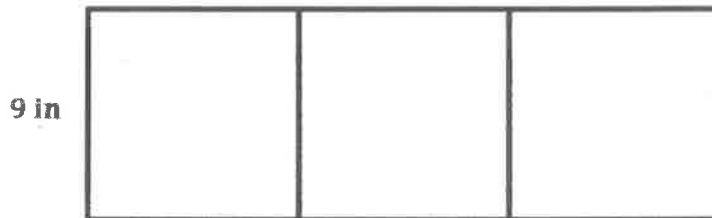

$$P = 8 \times 9 \text{ in} \\ = 72 \text{ in}$$

The side length of each square paper is 9 in. I can count to find that 8 sides of the squares make up the perimeter of the banner.
 $8 \times 9 \text{ in} = 72 \text{ in}$

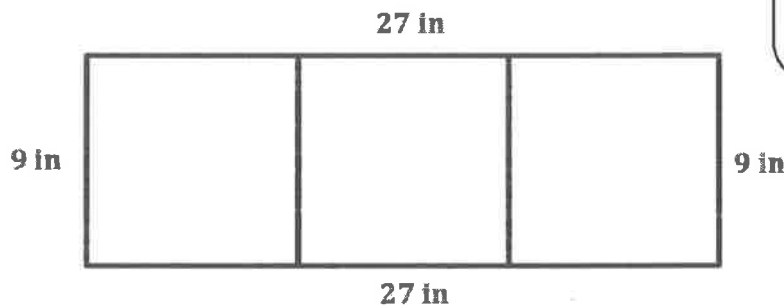

$$P = 9 \text{ in} + 9 \text{ in} + 27 \text{ in} + 27 \text{ in} \\ = 72 \text{ in}$$

The total perimeter of Caitlyn's banner is 72 inches.

Another strategy is to first find the side lengths of the rectangle. I know one side of the rectangle is still 9 in, but the other side tripled to 27 in. I can add all the side lengths together, but it's not a very friendly problem. Multiplying, like I did above, is a little easier.

- e. What is the total area of Caitlyn's banner?

$$A = (3 \times 81 \text{ sq in}) \\ = (3 \times 80 \text{ sq in}) + (3 \times 1 \text{ sq in}) \\ = 240 \text{ sq in} + 3 \text{ sq in} \\ = 243 \text{ sq in}$$

I can use the break apart and distribute strategy to help me find the answer to this challenging multiplication equation. I can first think of 3×80 in unit form as 3×8 tens = 24 tens, which has a value of 240. Then, I just have to remember to add the product of 3×1 .

The total area of Caitlyn's banner is 243 square inches.

G3-M7-Lesson 29

Josh puts two rectangles together to make the L-shaped figure below. He measures some of the side lengths and records them as shown.

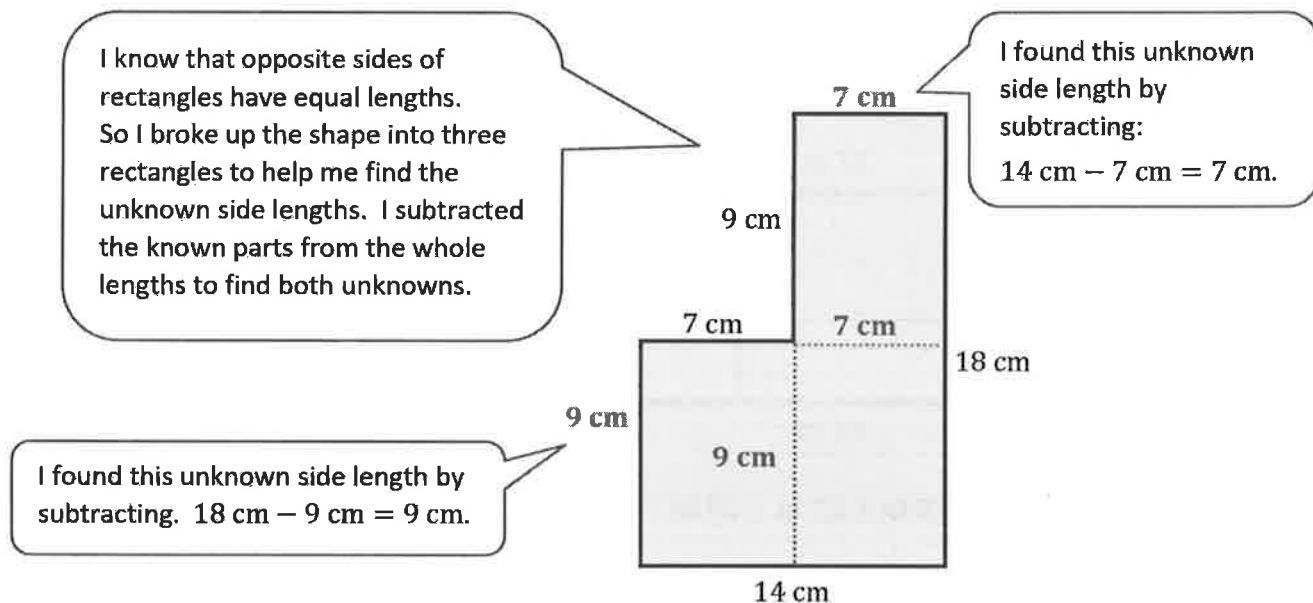

- a. Find the perimeter of Josh's shape.

$$\begin{aligned}
 P &= (2 \times 18\text{ cm}) + (2 \times 14\text{ cm}) \\
 &= 36\text{ cm} + 28\text{ cm} \\
 &= 64\text{ cm}
 \end{aligned}$$

The perimeter of Josh's shape is 64 cm.

- b. Find the area of Josh's shape.

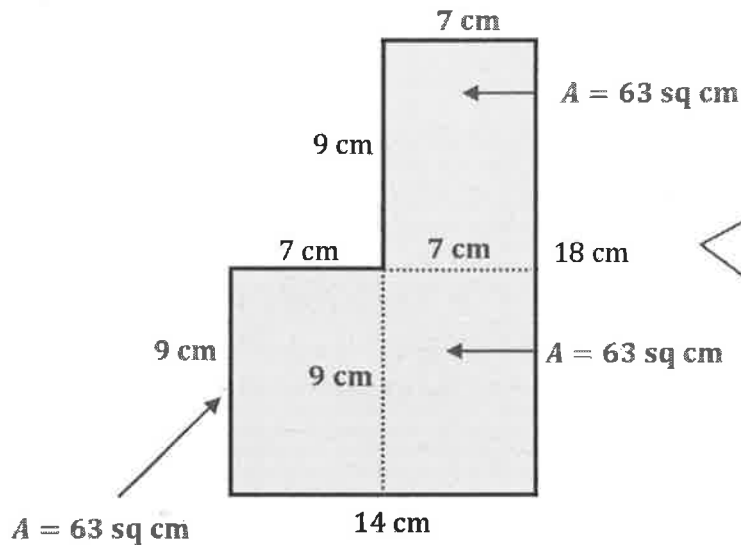

There are many ways to break up this shape. I chose to break it up into 3 rectangles and find the areas of each. I found that each of the three rectangles has an area of 63 sq cm. To find the total area of the shape, I can just add 63 three times or write a multiplication sentence.

$$\begin{aligned}
 A &= 3 \times 63 \text{ sq cm} \\
 &= (3 \times 60 \text{ sq cm}) + (3 \times 3 \text{ sq cm}) \\
 &= 180 \text{ sq cm} + 9 \text{ sq cm} \\
 &= 189 \text{ sq cm}
 \end{aligned}$$

I can use unit form language to help me solve 3×60 . It's the same as 3×6 tens. That's equal to 18 tens, which has a value of 180.

The area of Josh's shape is 189 sq cm.

G3-M7-Lesson 30

Andrew solves the following problem as shown below.

A basketball court measures 74 feet by 52 feet. Bill dribbles the basketball around the court sidelines 3 times. What is the total number of feet Bill dribbles the ball?

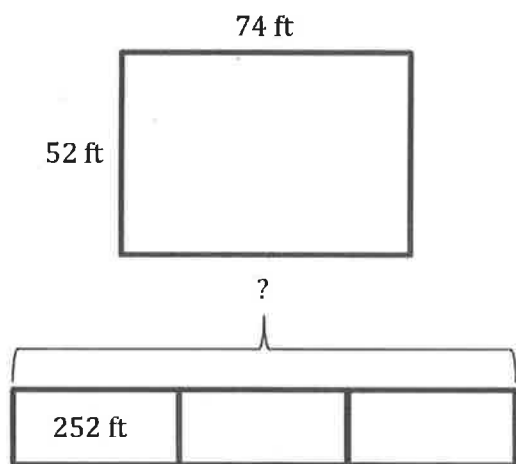

$$\begin{aligned} P &= 52 \text{ ft} + 74 \text{ ft} + 52 \text{ ft} + 74 \text{ ft} \\ &= 126 \text{ ft} + 126 \text{ ft} \\ &= 252 \text{ ft} \end{aligned}$$

$$\begin{aligned} &252 + 252 + 252 \\ &= 750 + 6 \\ &= 756 \end{aligned}$$

Bill dribbles the ball 756 feet.

1. What strategies did Andrew use to solve this problem?

Andrew drew a picture of the basketball court and labeled the side lengths. Then he added to find the perimeter. Finally, he used a tape diagram to find the total of 3 perimeters.

Analyzing my classmates' work improves my problem-solving skills because I am able to see different and sometimes more efficient ways of solving a problem.

2. What did Andrew do well?

Andrew used all the steps in the RDW process. He used mental math for his calculations. He also drew and labeled a tape diagram to show his thinking for his second step.

3. What are some suggestions that you would give Andrew to improve his work?

Some suggestions would be to have Andrew use a letter to represent the unknown in the tape diagram and label all of the units in his addition sentence.

4. What are some strategies you would like to try based on Andrew's work?

I would like to practice thinking about numbers like $252 + 252 + 252$ as $(250 + 250 + 250) + (2 + 2 + 2)$. That will help me use mental math strategies to add and not have to use the algorithm as much.

Having classmates analyze my work is helpful because I am able to get ideas on how to improve it.

G3-M7-Lesson 31

1. Use the rectangle below to answer Problem 1 (a)–(d).

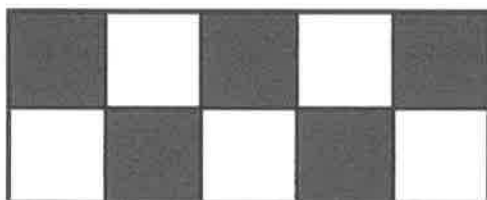

- a. What is the area of the rectangle in square units?

The area of the rectangle is 10 square units.

I can find the area by multiplying the side lengths.

$$2 \times 5 = 10$$

Or, I can count the square units. Either way the answer is the same!

- b. What is the area of half of the rectangle in square units?

$$10 \div 2 = 5$$

The area of half of the rectangle is 5 square units.

I can divide the total area by 2 to find the area of half of the rectangle.

- c. Shade in half of the rectangle above. Be creative with your shading!

I can use my answer to part (b) to help me shade in half of the rectangle.

- d. Explain how you know you shaded in half of the rectangle.

I know I shaded in half of the rectangle because I shaded 5 square units and the area of half of the rectangle is 5 square units.

2. During art class, Mia draws a shape and then shades one-half of it. Analyze Mia's work. Determine if she was correct or not, and explain your thinking.

Mia's Drawing	Your Analysis
	<p><i>Mia did not correctly shade one-half of her drawing. There is less than one-half of the drawing shaded because of the unshaded heart in the shaded part of the drawing. She needs to shade a same-sized heart in the unshaded part to show one-half shaded.</i></p>

I can picture what Mia's drawing might look like if she had shaded it correctly. It might look like this:



3. Shade the grid below to show two different ways of shading half of each shape.

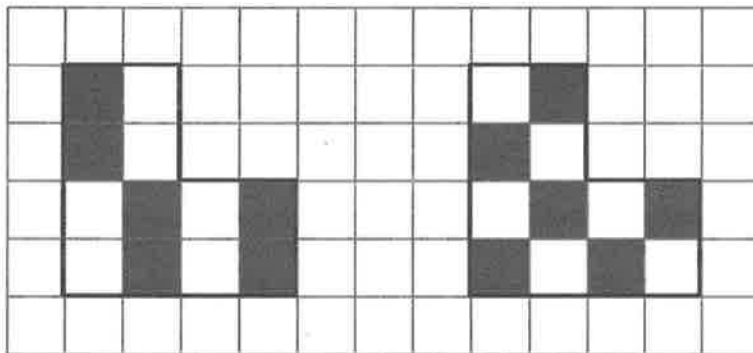

I can find the total area for each shape by counting the square units. Then I can divide that number by 2 to figure out how many square units to shade in order to show one-half. I can shade in 6 square units for each shape.

$$12 \div 2 = 6$$

G3-M7-Lesson 32

1. Estimate to finish shading the circle below so that it is about one-half shaded.

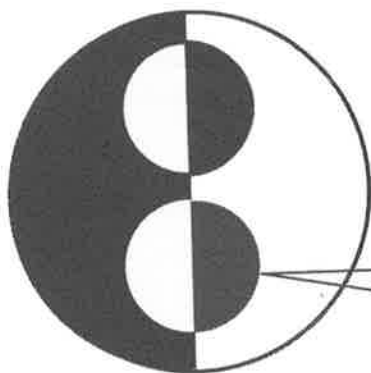

I can shade in another half circle that is about the same size as the unshaded half circle.

2. Explain how you know the circle in Problem 1 is about one-half shaded.

I know the circle in Problem 1 is about one-half shaded because I can picture the little shaded half circles flipped over and moved into the shaded part of the circle. Then it would be easy to see that the circle is about one-half shaded because it would look like this:

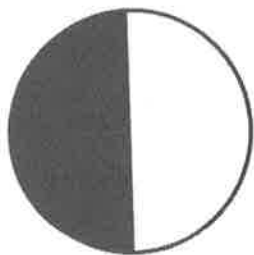

I can also picture the large shaded part flipped over onto the unshaded part. Then the circle would look like this:

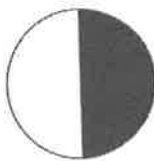

Either way, it's easy to see that it's about one-half shaded.

3. Can you say the circle in Problem 1 is exactly one-half shaded? Why or why not?

No, I can't say that the circle in Problem 1 is exactly one-half shaded because there aren't any gridlines, and I had to estimate to shade the little half circle. When I estimate, I know my answer isn't exact.

I can also tell the circle is not exactly one-half shaded because the directions for Problems 1 and 2 use the word *about*. When I see the word *about* I know the answer is not exact; it's an estimate.

4. Wilson and Laurie shade in circles as shown below.

Wilson's Circle



Laurie's Circle



- a. Whose circle is about one-half shaded? How do you know?

Laurie's circle is about one-half shaded. I can picture the image in the top part of the circle flipped over and moved to the bottom of the circle. Then the bottom half of Laurie's circle would be all shaded, which means the whole circle would be about one-half shaded.

I see that the shaded amount is about the same as the unshaded amount in Laurie's circle. That means that Laurie's circle is about one-half shaded.

- b. Explain how the circle that is not one-half shaded can be changed so that it is one-half shaded.

Wilson's circle has too much shading. He needs to erase a small shaded circle in one of the shaded parts that matches the small shaded circle.

Or, Wilson can erase the small shaded circle. Then his whole circle would be about one-half shaded.

G3-M7-Lesson 33

Teach a family member your favorite fluency game from class. Record information about the game you taught below.

Name of the game:

Partition Shapes

Materials used:

The only materials we needed were personal white boards and markers.

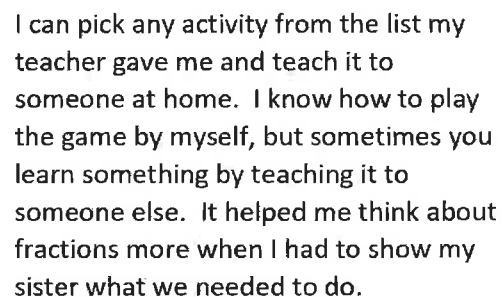

I can pick any activity from the list my teacher gave me and teach it to someone at home. I know how to play the game by myself, but sometimes you learn something by teaching it to someone else. It helped me think about fractions more when I had to show my sister what we needed to do.

Name of the person you taught to play:

I taught my sister Sonia to play.

Describe what it was like to teach the game. Was it easy? Hard? Why?

I'm used to learning games from my teacher and then playing with friends. Teaching someone else was fun, but it was tricky. Even though I know how to play the game, I realized after we started that I forgot to explain some of the important parts.

Will you play the game together again? Why or why not?

Yes. We liked drawing shapes on our personal white boards. My sister didn't know about fractions, and I got to show her. I liked that. We'll try different games sometimes too.

Was the game as fun to play at home as in class? Why or why not?

It was really fun to play at home because I also got to teach it to my sister.